

Scalable IP Lookup for Internet Routers

David E. Taylor, Jonathan S. Turner, *Fellow, IEEE*, John W. Lockwood, *Member, IEEE*, Todd S. Sproull, and David B. Parlour, *Member, IEEE*

Abstract—Internet protocol (IP) address lookup is a central processing function of Internet routers. While a wide range of solutions to this problem have been devised, very few simultaneously achieve high lookup rates, good update performance, high memory efficiency, and low hardware cost. High performance solutions using content addressable memory devices are a popular but high-cost solution, particularly when applied to large databases. We present an efficient hardware implementation of a previously unpublished IP address lookup architecture, invented by Eatherton and Dittia. Our experimental implementation uses a single commodity synchronous random access memory chip and less than 10% of the logic resources of a commercial configurable logic device, operating at 100 MHz. With these quite modest resources, it can perform over 9 million lookups/s, while simultaneously processing thousands of updates/s, on databases with over 100000 entries. The lookup structure requires 6.3 bytes per address prefix: less than half that required by other methods. The architecture allows performance to be scaled up by using parallel fast IP lookup (FIPL) engines, which interleave accesses to a common memory interface. This architecture allows performance to scale up directly with available memory bandwidth. We describe the Tree Bitmap algorithm, our implementation of it in a dynamically extensible gigabit router being developed at Washington University in Saint Louis, and the results of performance experiments designed to assess its performance under realistic operating conditions.

Index Terms—Field-programmable gate array (FPGA), Internet router, IP lookup, random access memory (RAM), reconfigurable hardware.

I. INTRODUCTION

FORWARDING of Internet protocol (IP) packets is the primary purpose of Internet routers. The speed at which forwarding decisions are made at each router or “hop” places a fundamental limit on the performance of the network. For Internet Protocol Version 4 (IPv4), the forwarding decision is based on a 32-bit destination address carried in each packet’s header. A lookup engine at each port of the router uses a suitable routing data structure to determine the appropriate outgoing link for the packet’s destination address.

The use of classless interdomain routing (CIDR) complicates the lookup process, requiring a lookup engine to search variable-length address prefixes in order to find the longest matching prefix of the destination address and retrieve the corresponding

forwarding information [1]. As physical link speeds grow and the number of ports in high-performance routers continues to increase, there is a growing need for efficient lookup algorithms and effective implementations of those algorithms. Next-generation routers must be able to support thousands of optical links each operating at 10 Gb/s (OC-192) or more. Lookup techniques that can scale efficiently to high speeds and large lookup table sizes are essential for meeting the growing performance demands, while maintaining acceptable per-port costs.

Many techniques are available to perform IP address lookups. Perhaps the most common approach in high-performance systems is to use content addressable memory (CAM) devices and custom application-specific integrated circuits (ASICs). While this approach can provide excellent performance, the performance comes at a fairly high price due to the high-cost per bit of CAMs relative to commodity memory devices. CAM approaches also offer little or no flexibility for adapting to new addressing and routing protocols. A brief overview of related lookup techniques is provided in Section II.

The fast Internet protocol lookup (FIPL) architecture, developed at Washington University in Saint Louis, is an experimental implementation of Eatherton and Dittia’s previously unpublished Tree Bitmap algorithm [2] using reconfigurable hardware and random access memory (RAM). FIPL is designed to strike a favorable balance among lookup and update performance, memory efficiency, and hardware usage. Targeted to an open-platform research router employing a Xilinx Virtex 1000E-7 field programmable gate array (FPGA) operating at 100 MHz and a single Micron 1-MB zero bus turnaround (ZBT) synchronous random access memory (SRAM), a single FIPL lookup engine has a guaranteed worst-case performance of 1 136 363 lookups/s. Interleaving memory accesses of eight FIPL engines over a single 36-bit wide SRAM interface exhausts the available memory bandwidth and yields a guaranteed worst-case performance of 9 090 909 lookups/s.

Performance evaluations using a snapshot of the Mae–West routing table resulted in over 11 million lookups/s for an optimized eight FIPL engine configuration. Average memory usage per entry was 6.3 bytes, less than twice the number of bits required to represent an individual prefix. In addition to space efficiency, the data structure used by FIPL is straightforward to update and can support up to 100 000 updates/s with only a 7.2% degradation in lookup throughput. Each FIPL engine utilizes less than 1% of the available logic resources on the target FPGA. While this search engine currently achieves 500 Mb/s of link traffic per 1% of logic resources, still higher performance and efficiency is possible with higher memory bandwidths. Ongoing research seeks to exploit new FPGA devices and more advanced CAD tools in order to double the clock frequency and, therefore, double the lookup performance. We also are investigating optimizations to reduce the number of off-chip

Manuscript received August 1, 2002; revised August 27, 2002. This work supported in part by the National Science Foundation (NSF) under Grant ANI-0096052 and in part by Xilinx, Inc.

D. E. Taylor, J. S. Turner, J. W. Lockwood, and T. S. Sproull are with the Applied Research Laboratory, Washington University in Saint Louis, St. Louis, MO 63130 USA (e-mail: det3@arl.wustl.edu; jst@arl.wustl.edu; lockwood@arl.wustl.edu; todd@arl.wustl.edu).

D. B. Parlour is with Xilinx, Inc., Pittsburg, PA 15213 USA (e-mail: dave.parlour@xilinx.com).

Digital Object Identifier 10.1109/JSAC.2003.810507

memory accesses. Another research effort leverages the insights and components produced by the FIPL implementation for an efficient route lookup and packet classifier for an open-platform dynamically extensible research router [3].

II. RELATED WORK

Numerous research and commercial IP lookup techniques exist [4]–[7]. On the commercial front, several companies have developed high-speed lookup techniques using CAMs and ASICs. Some current products, targeting OC-768 (40 Gb/s) and quad OC-192 (10 Gb/s) link configurations, claim throughputs of up to 100 million lookups/s and storage for 100 million entries [8]. However, the advertised performance comes at an extreme cost. Sixteen ASICs containing embedded CAMs must be cascaded in order to achieve the advertised throughput and support the more realistic storage capacity of one million table entries. Such exorbitant hardware resource requirements make these solutions prohibitively expensive and preclude system-on-chip (SOC) port processors.

The most efficient lookup algorithm known, from a theoretical perspective, is the “binary search over prefix lengths” algorithm described in [9]. The number of steps required by this algorithm grows logarithmically in the length of the address, making it particularly attractive for IPv6, where address lengths increase to 128 bits. However, the algorithm is relatively complex to implement, making it more suitable for software implementation than hardware implementation. It also does not readily support incremental updates.

The Lulea algorithm is the most similar of published algorithms to the Tree Bitmap algorithm used in our FIPL engine [7]. Like Tree Bitmap, the Lulea algorithm uses a type of compressed trie to enable high-speed lookup, while maintaining the essential simplicity and easy updatability of elementary binary tries. While similar at a high level, the two algorithms differ in a variety of specifics that make Tree Bitmap somewhat better suited to efficient hardware implementation. A detailed comparison of the Tree Bitmap algorithm to other published lookup techniques is provided in [2].

The remaining sections provide an overview of the algorithm and focus on the design and implementation details of a fast and scalable lookup architecture based on Tree Bitmap. We also present performance evaluations of FIPL under realistic operating conditions, including incremental update performance under full traffic load. We conclude with algorithmic and implementation optimizations for improving lookup performance and discuss ongoing research projects employing the FIPL engine.

III. TREE BITMAP ALGORITHM

Eatherton and Dittia’s Tree Bitmap algorithm is a hardware based algorithm that employs a multibit trie data structure to perform IP forwarding lookups with efficient use of memory [2]. Due to the use of CIDR, a lookup consists of finding the longest matching prefix stored in the forwarding table for a given 32-bit IPv4 destination address and retrieving the associated forwarding information. As shown in Fig. 1, the unicast IP address is compared to the stored prefixes starting with the most significant bit. In this example, a packet is bound for a

Prefix	Next Hop
*	35
10*	7
01*	21
110*	9
1011*	1
0001*	68
01011*	51
001110*	3
10001*	6
100001*	33
10000000*	54
1000000000*	12
1000000011*	7

32-bit IP Address

128.252.153.160
1000 0000 1111 1100 ... 1010 0000

Next Hop

7

Fig. 1. IP prefix lookup table of next hops. Next hops for IP packets are found using the longest matching prefix in the table for the unicast destination address of the IP packet.

workstation at Washington University in Saint Louis. A linear search through the table results in three matching prefixes: (*), 10*, and 1000 0000 11*. The third prefix is the longest match, hence, its associated forwarding information, denoted by Next Hop 7 in the example, is retrieved. Using this forwarding information, the packet is forwarded to the specified next hop by modifying the packet header.

To efficiently perform this lookup function in hardware, the Tree Bitmap algorithm starts by storing prefixes in a binary trie as shown in Fig. 2. Shaded nodes denote a stored prefix. A search is conducted by using the IP address bits to traverse the trie, starting with the most significant bit of the address. To speed up this searching process, multiple bits of the destination address are compared simultaneously. In order to do this, subtrees of the binary trie are combined into single nodes producing a multibit trie; this reduces the number of memory accesses needed to perform a lookup. The depth of the subtrees combined to form a single multibit trie node is called the stride. An example of a multibit trie using 4-bit strides is shown in Fig. 3. In this case, 4-bit nibbles of the destination address are used to traverse the multibit trie. Address_Nibble(0) of the address, 1000₂ in the example, is used for the root node; Address_Nibble(1) of the address, 0000₂ in the example, is used for the next node; etc.

The Tree Bitmap algorithm codes information associated with each node of the multibit trie using bitmaps. The *Internal Prefix Bitmap* identifies the stored prefixes in the binary subtree of the multibit node. The *Extending Paths Bitmap* identifies the “exit points” of the multibit node that correspond to child nodes. Fig. 4 shows how the root node of the example data structure is coded into bitmaps. The 4-bit stride example is shown as a Tree Bitmap data structure in Fig. 5. Note that a pointer to the head of the array of child nodes and a pointer to

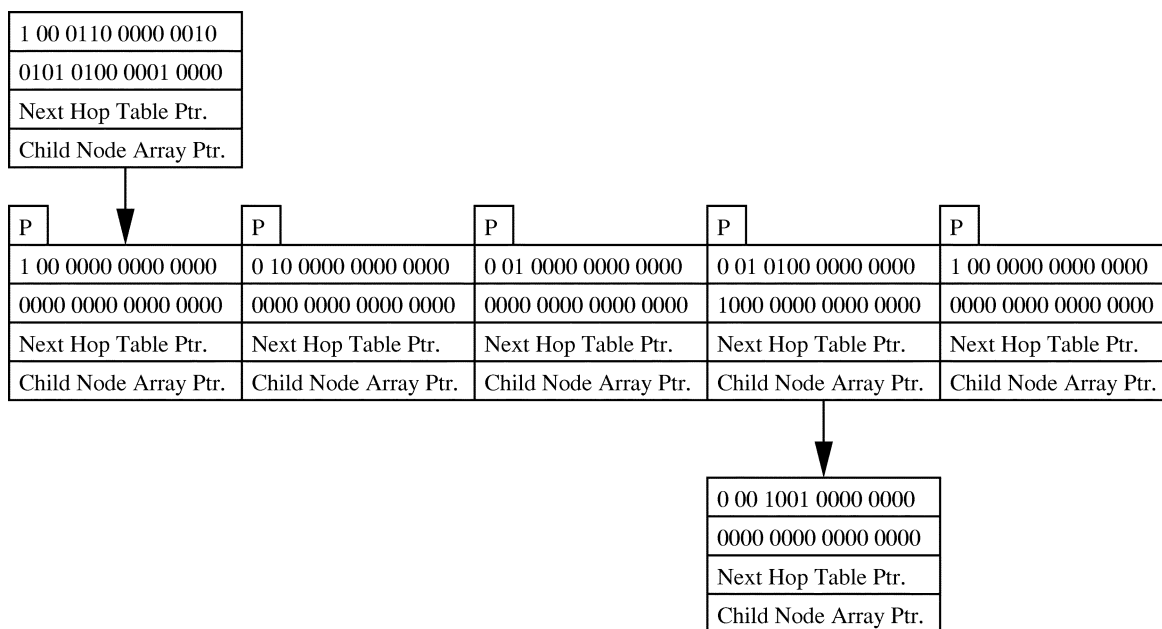

Fig. 5. IP lookup table represented as a Tree Bitmap. Child nodes are stored contiguously so that a single pointer and an index may be used to locate any child node in the data structure.

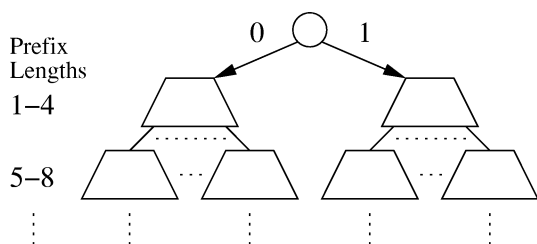

Fig. 6. Split-trie optimization of the Tree Bitmap data structure.

nodes in the data structure, represented as a multibit node with a single prefix stored at the root in the “single-trie” configuration. Such nodes carry very little information and make poor use of the memory they consume.

The “split-trie” optimization seeks to speed up lookup performance and reduce memory usage for typical databases by shifting “multiple of four” prefixes up one level in the data structure. This can easily be achieved by splitting the multibit trie into two multibit tries with a root node having a stride of one, as shown in Fig. 6. Implementation of this optimization requires two pointers (one to each new multibit root node) and a next hop value for the root node (default route). Searches begin by using the most significant bit of the destination address to decide from which multibit root node to perform the search. For most lookups on typical databases, this optimization saves one memory access per lookup and reduces the memory space per prefix required for the Tree Bitmap data structure. The lookup performance and memory utilization of both the “single-trie” and “split-trie” configurations of the FIPL architecture are evaluated in Section VI.

IV. HARDWARE DESIGN AND IMPLEMENTATION

Modular design techniques are employed throughout the FIPL hardware design to provide scalability for various system

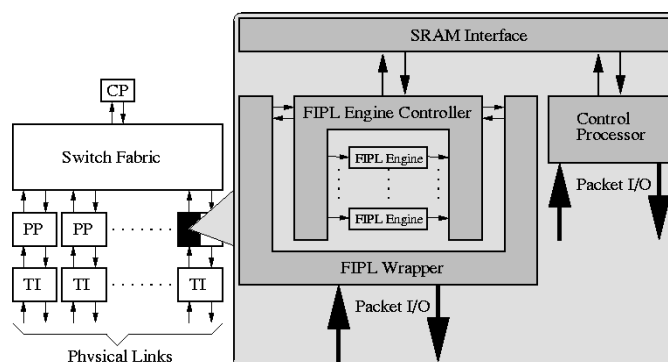

Fig. 7. Block diagram of router with multiengine FIPL configuration; detail of FIPL system components in the port processor (PP).

configurations. Fig. 7 details the components required to implement FIPL in the port processor (PP) of a router. Other components of the router include the transmission interfaces (TI), switch fabric, and control processor (CP). Providing the foundation of the FIPL design, the FIPL engine implements a single instance of a Tree Bitmap search. The FIPL engine controller may be configured to instantiate multiple FIPL engines in order to scale the lookup throughput with system demands. The FIPL wrapper extracts the IP addresses from incoming packets and writes them to an address FIFO read by the FIPL engine controller. Lookup results are written to a FIFO read by the FIPL wrapper, which accordingly modifies the packet header. The FIPL wrapper also handles standard IP processing functions such as checksums and header field updates. Specifics of the FIPL wrapper will vary, depending upon the type of switching core and transmission format. An on-chip CP receives and processes memory update commands on a dedicated control channel. Memory updates are the result of route add, delete, or modify commands and are sent from

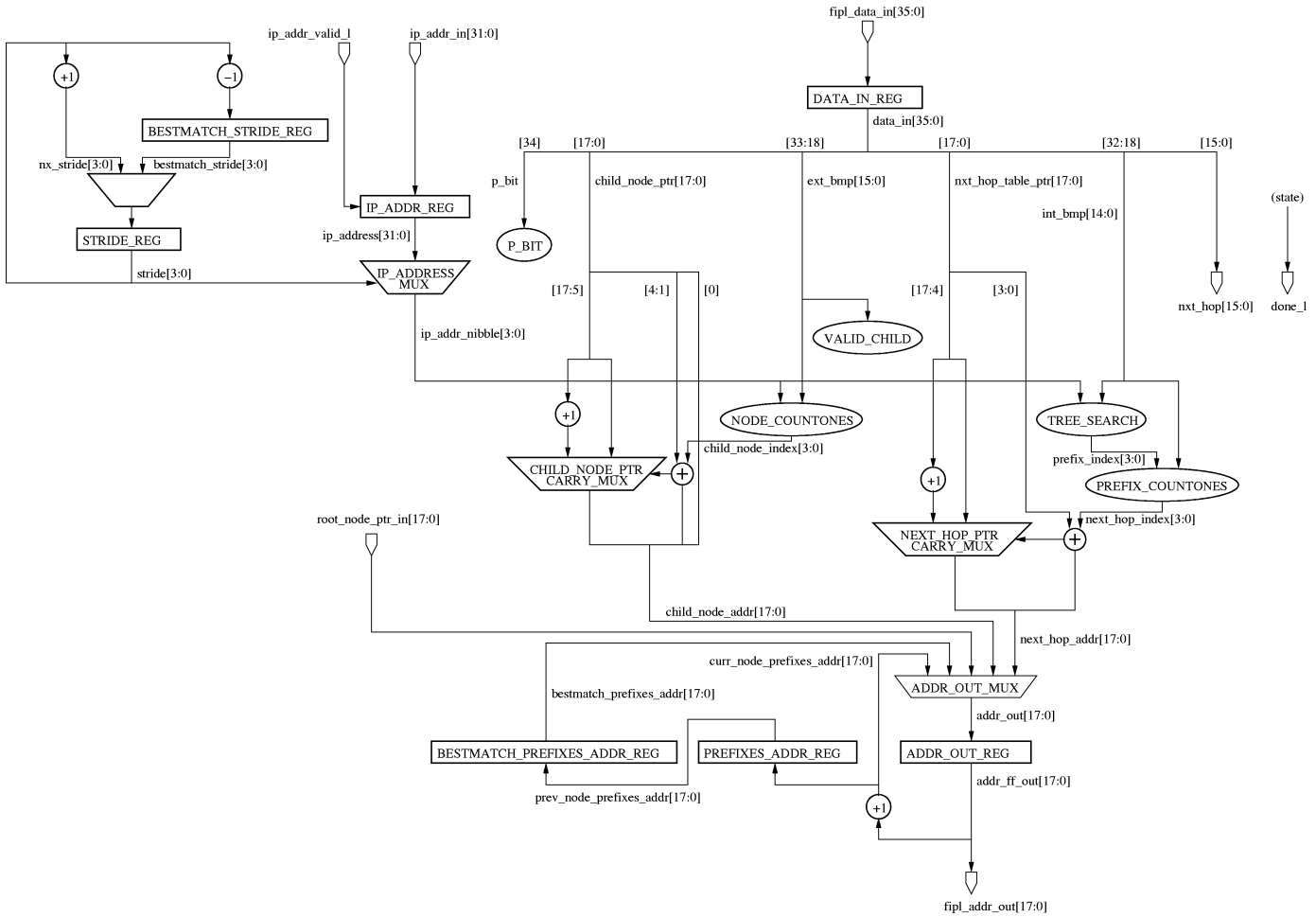

Fig. 8. FIPL engine dataflow; multicycle path from input data flops to output address flops can be scaled according to target device speed; all multiplexor select lines and flip-flop enables implicitly driven by finite-state machine (FSM) outputs.

the system management and control components. Note that the off-chip memory is assumed to be a single port device; hence, an SRAM interface arbitrates access between the FIPL engine controller and CP.

A. FIPL Engine

Consisting of a few address registers, a simple finite-state machine (FSM), and combinational logic, the FIPL engine is a compact, efficient Tree Bitmap search engine. Implementation of the FIPL engine requires only 450 lines of VHDL code. A dataflow diagram of the FIPL engine is shown in Fig. 8. Data arriving from memory is latched into the DATA_IN_REG register n clock cycles after issuing a memory read. The value of n is determined by the read latency of the memory device plus two clock cycles for latching the address out of and the data into the implementation device. The next address issued to memory is latched into the ADDR_OUT_REG k clock cycles after data arrives from memory. The value of k is determined by the speed at which the implementation device can compute the *next_hop_addr*, which is the critical path in the logic. Two counters (*mem_count* and *search_count*) are used to count the number of clock cycles for memory access and address calculation, respectively. Use of multicycle paths allows the FIPL en-

gine to scale with implementation device and memory device speeds by simply changing compare values in the FSM logic.

In order to generate *next_hop_addr*, the FIPL engine does the following.

- TREE_SEARCH generates *prefix_index*, which is the bit position of the best-matching prefix stored in the *Internal Prefixes Bitmap*.
- PREFIX_COUNTONES generates *next_hop_index* which is the number of 1's to the left of *prefix_index* in the *Internal Prefixes Bitmap*.
- *next_hop_index* is added to the lower four bits of the *Next Hop Table Pointer*.
- The carryout of the previous addition is used to select the upper bits of the *Next Hop Table Pointer* or the precomputed value of the upper bits plus one.

The NODE_COUNTONES and identical fast addition blocks generate the *child_node_addr* but require less time as the TREE_SEARCH block is not in the path. The ADDR_OUT_MUX selects the next address issued to memory among the addresses for the root node's *Extending Paths Bitmap* and *Child Node Array Pointer* (*root_node_ptr*), the next child node's *Extending Paths Bitmap* and *Child Node Array Pointer* (*child_node_addr*),

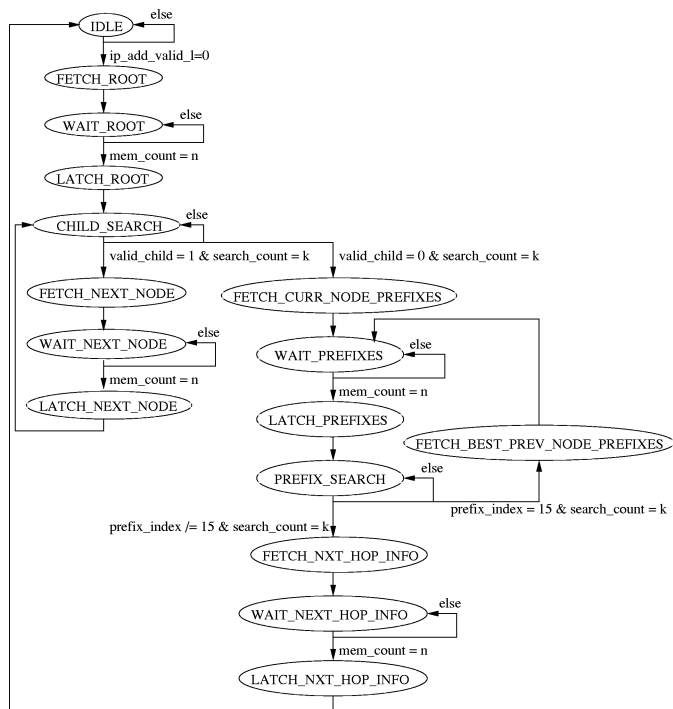

Fig. 9. FIPL engine state transition diagram.

the current node’s *Internal Prefix Bitmap* and *Next Hop Table Pointer* (*curr_node_prefixes_addr*), the forwarding information for the best-matching prefix (*next_hop_addr*), and the best-matching previous node’s *Internal Prefix Bitmap* and *Next Hop Table Pointer* (*bestmatch_prefixes_addr*). Selection is made based upon the current state.

VALID_CHILD examines the *Extending Paths Bitmap* and determines if a child node exists for the current node based on the current nibble of the IP address. The output of VALID_CHILD, *prefix_index*, *mem_count*, and *search_count* determine state transitions as shown in Fig. 9. The current state and the value of the P_BIT determine the register enables for the BESTMATCH_PREFIXES_ADDR_REG and the BESTMATCH_STRIDE_REG which store the address of the *Internal Prefixes Bitmap* and *Next Hop Table Pointer* of the node containing best-matching prefixes and the associated stride of the IP address, respectively.

B. FIPL Engine Controller

Leveraging the uniform memory access period of the FIPL engine, the FIPL engine controller interleaves memory accesses of the necessary number of parallel FIPL engines to scale lookup throughput in order to meet system throughput demands. The scheme centers around a timing wheel with a number of slots equal to the FIPL engine memory access period. When an address is read from the input FIFO, the next available FIPL engine is started at the next available time slot. The next available time slot is determined by indexing the current slot time by the known startup latency of a FIPL engine. For example, assume an access period of eight clock cycles; hence, the timing wheel has eight slots numbered zero through seven. Assume three FIPL engines are currently performing lookups occupying slots 1, 3, and 4. Furthermore, assume that from the time the IP address is issued

to the FIPL engine to the time the FIPL engine issues its first memory read is two clock cycles; hence, the startup latency is two slots. When a new IP address arrives, the next lookup may not be started at slot times 7, 1, or 2 because the first memory read would be issued at slot time 1, 3, or 4, respectively, which would interfere with ongoing lookups. Assume the current slot time is three; therefore, the next FIPL engine is started, and slot 5 is marked as occupied.

As previously mentioned, input IP addresses and output forwarding information are passed between the FIPL engine controller and the FIPL wrapper via FIFO interfaces. This design simplifies the design of the FIPL wrapper by placing the burden of in-order delivery of results on the FIPL engine controller. While individual input and output FIFOs could be used for each engine to prevent head-of-the-line blocking, network designers will usually choose to configure the FIPL engine controller assuming worst-case lookups. Also, the performance numbers reported in a subsequent section show that average lookup latency per FIPL engine increases by less than 3% for an eight-engine configuration; therefore, lookup engine “dead time” is negligible.

C. Implementation Platform

FIPL is implemented on open-platform research systems designed and built at Washington University in Saint Louis [10]. The WUGS 20, an eight-port ATM switch providing 20 Gb/s of aggregate throughput, provides a high-performance switching fabric [11]. This switching core is based upon a multistage Benes topology, supports up to 2.4-Gb/s link rates, and scales up to 4096 ports for an aggregate throughput of 9.8 Tb/s [12]. Each port of the WUGS 20 can be fitted with a Field-programmable Port eXtender (FPX), which is a port card of the same form factor as the WUGS transmission interface cards [13]. Each FPX contains two FPGAs: one acting as the Network Interface Device (NID) and the other as the Reprogrammable Application Device (RAD).

The RAD FPGA has access to two 1-MB ZBT SRAMs and two 64-MB SDRAM modules providing a flexible platform for implementing high-performance networking applications [14]. To allow for packet reassembly and other processing functions requiring memory resources, the FIPL has access to one of the 8 Mb ZBT SRAMs which require 18-bit addresses and provide a 36-bit data path with a two-clock cycle latency. Since this memory is “off-chip,” both the address and data lines must be latched at the pads of the FPGA, providing for a total latency to memory of $n = 4$ clock cycles.

D. Memory Configuration

Utilizing a 4-bit stride the *Extending Paths Bitmap* is 16-bits long, occupying less than a half-word of memory. The remaining 20-bits of the word are used for the *Prefix Bit* and *Child Node Array Pointer*; hence, only one memory access is required per node when searching for the terminal node. Likewise, the *Internal Prefix Bitmap* and *Next Hop Table Pointer* may be stored in a single 36-bit word; hence, a single node of the Tree Bitmap requires two words of memory space. In one of the 8-Mb SRAMs, 131 072 nodes may be stored providing a maximum of 1 966 080 stored routes. Note

that the memory usage per route entry is dependent upon the distribution of prefixes in the data structure. Memory usage for the experimental data structure is reported in the Section VI.

E. Worst-Case Performance

In this configuration, the pathological lookup requires 11 memory accesses: eight memory accesses to reach the terminal node, one memory access to search the subtree of the terminal node, one memory access to search the subtree of the most recent node containing a match, and one memory access to fetch the forwarding information associated with the best-matching prefix. Since the FPGAs and SRAMs run on a synchronous 100 MHz clock, all single cycle calculations must be completed in less than 10 ns. The critical path in the FIPL design, resolving the *next_hop_addr*, requires more than 20 ns when targeted to the RAD FPGA of the FPX, a Xilinx XCV1000E-7; hence, k is set to three. This provides a total memory access period of 80 ns and requires eight FIPL engines in order to fully utilize the available memory bandwidth. Theoretical worst-case performance, all lookups requiring 11 memory accesses, ranges from 1 136 363 lookups/s for a single FIPL engine to 9 090 909 lookups/s for eight FIPL engines in this implementation environment.

F. Hardware Resource Usage

As the WUGS 20 supports a maximum line speed of 2.4 Gb/s, a four-engine configuration is used in the Washington University system. Due to the ATM switching core, the FIPL wrapper supports AAL5 encapsulation of IP packets inside of ATM cells [15]. Relative to the Xilinx Virtex 1000E FPGA used in the FPX, each FIPL engine utilizes less than 1% of the available logic resources. Configured with four FIPL engines, FIPL engine controller utilizes approximately 6% of the logic resources while the FIPL wrapper utilizes another 2% of the logic resources and 12.5% of the on-chip memory resources. This results in an 8% total logic resource consumption by FIPL. The SRAM Interface and CP which parses control cells and executes memory commands for route updates utilize another 8% of the available logic resources and 2% of the on-chip memory resources. Therefore, all input IP forwarding functions occupy 16% of the logic resources leaving the remaining 84% of the device available for other packet processing functionality.

V. SYSTEM MANAGEMENT AND CONTROL COMPONENTS

System management and control of FIPL in the Washington University system is performed by several distributed components. All components were developed to facilitate further research using the open-platform system.

A. NCHARGE

NCHARGE is the software component that controls reprogrammable hardware on a switch [16]. Fig. 10 shows the role of NCHARGE in conjunction with multiple FPX devices within a switch. The software provides connectivity between each FPX and multiple remote software processes via TCP sockets that listen on a well-defined port. Through this port, other software

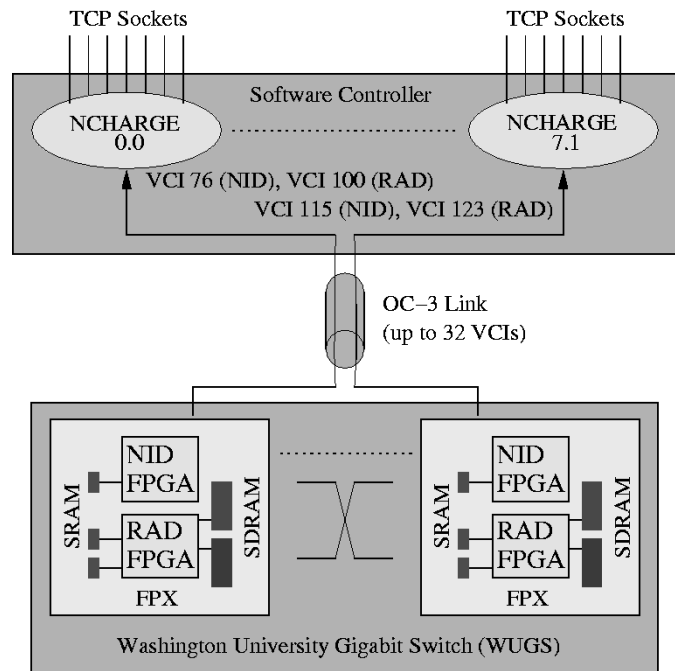

Fig. 10. Control of the FPX via NCHARGE software. Each FPX is controlled by an instance of NCHARGE which provides an API for FPX control via remote software process.

components are able to communicate to the FPX using its specified API. Because each FPX is controlled by an independent NCHARGE software process, distributed management of entire systems can be performed by collecting data from multiple NCHARGE elements. [17].

B. FIPL Memory Manager

The FIPL memory manager is a stand alone C++ application that accepts commands to add, delete, and update routing entries for a hardware-based Internet router. The program maintains the previously discussed Tree Bitmap data structure in a shared memory between hardware and software. When a user enters route updates, the FIPL memory manager software returns the corresponding memory updates needed to perform that operation in the FPX hardware.

Command options:

```
[A]dd
[D]elete
[C]hange
[P]rint
[M]emoryDump
[Q]uit
```

Enter command (h for help): A

You entered add

Enter prefix x.x.x.x/s

(x = 0 - 255, s is significant bits 0-32):
192.128.1.1/8

Enter Next Hop value: 4

Memory Update Commands:

```
w36 0 4 2 000 000 000 100 000 006
```

```
w36 0 2 2 200 000 004 000 000 000
```

```
w36 0 0 2 000 200 002 000 000 000
```

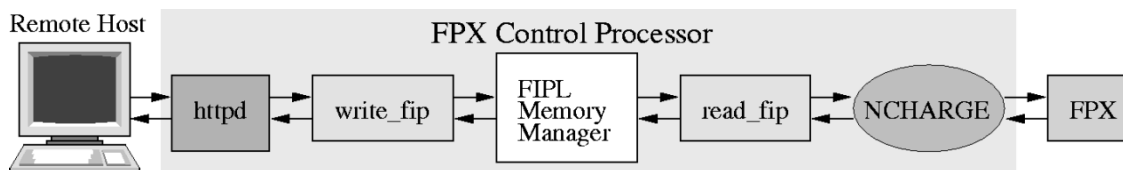

Fig. 11. Command flow for control of FIPL via a remote host.

In the example shown here, a single add route command requires three 36-bit memory write commands, each consisting of two consecutive locations in memory at addresses 4, 2, and 0, respectively.

C. Sockets Interfaces

In order to access the FIPL memory manager as a daemon process, support software needs to be in place to handle standard input and output. Socket software was developed to handle incoming route updates to pass along to the FIPL memory manager. A socket interface was also developed to send the resulting output of a memory update to the NCHARGE software. These software processes handling input and output are called Write_Fip and Read_Fip, respectively. Write_Fip is constantly listening on a well known port for incoming route update commands. Once a connection is established the update command is sent as an ASCII character string to Write_Fip. This software prints the string as standard output which is redirected to the standard input of FIPL memory manager. The memory update commands needed by NCHARGE software to perform the route update are issued at the output of FIPL memory manager. Read_Fip receives these commands as standard input and sends all of the memory updates associated with one route update over a TCP socket to the NCHARGE software.

D. Remote User Interface

The current interface for performing route updates is via a web page that provides a simple interface for user interaction. The user is able to submit single route updates or a batch job of multiple routes in a file. Another option available to users is the ability to define unique control cells. This is done through the use of software modules that are loaded into the NCHARGE system.

In the current FIPL module, a web page has been designed to provide a simple interface for issuing FIPL control commands, such as changing the *Root Node Pointer*. The web page also provides access to a vast database of sample route table entries taken from the Internet Performance Measurement and Analysis project's website [18]. This website provides daily snapshots of Internet backbone routing tables including traditional Class A, B, and C addresses. Selecting the download option from the FIPL web page executes a Perl script to fetch the router snapshots from the database. The Perl script then parses the files and generates an output file that is readable by the fast IP lookup memory manager.

E. Command Flow

The overall flow of data with FIPL and NCHARGE is shown in Fig. 11. Suppose a user wishes to add a route to the data-

FAST IP LOOKUP

Port Number: Stack Level:

- Route Add IP Address: Net Mask: Next Hop:
- Route Delete IP Address: Net Mask:
- Route Modify IP Address: Net Mask: Next Hop:
- Submit Routes Filename:

Fig. 12. FPX Web Interface for FIPL route updates.

base. The user first submits either a single command or submits a file containing multiple route updates. Data submitted from the web page (see Fig. 12) is passed to the Web Server as a form. Local scripts process the form and generate an Add Route command that the software understands. These commands are ASCII strings in the form "Add route $A_1.A_2.A_3.A_4$ /netmask nexthop." The script then sets up a TCP socket and transmits each command to the Write_Fip software process. As mentioned before, Write_fip listens on a TCP port and relays messages to standard output in order to communicate with the FIPL memory manager. FIPL memory manager takes the standard input and processes the route command in order to generate memory updates for an FPX board. Each memory update is then passed as standard output to the Read_Fip process.

After this process collects memory updates it establishes a TCP connection with NCHARGE to transmit the commands. Read_Fip is able to detect individual route commands and issues the set of memory updates associated with each. This prevents Read_Fip from creating a socket for every memory update. From here, memory updates are sent to NCHARGE software process to be packed into control cells to send to the FPX. NCHARGE packs as many memory commands as it can fit into a 53 byte ATM cell while preserving order between commands. NCHARGE sends these control cells using a stop-and-wait protocol to ensure correctness, then issues a response message to the user.

VI. PERFORMANCE MEASUREMENTS

While the worst-case performance of FIPL is deterministic, an evaluation environment was developed in order to benchmark average FIPL performance on actual router databases. The evaluation environment was used to extract lookup and update performance as the number of parallel FIPL engines was scaled up, as well as determine the performance gain of the split-trie optimization. As shown in Fig. 13, the evaluation environment includes a modified FIPL engine controller, eight FIPL engines, and a FIPL evaluation wrapper. The FIPL evaluation wrapper includes an IP address generator which uses on-chip BlockRAMs

TABLE I
MEMORY USAGE FOR THE TREE BITMAP DATA STRUCTURE AND NEXT HOP INFORMATION USING A SNAPSHOT
OF THE MAE-WEST DATABASE FROM MARCH 15, 2002, CONSISTING OF 27,609 ROUTES

Type	Total (bytes)	Total (bytes/prefix)	Next Hop (bytes)	Next Hop (bytes/prefix)	Tree Bitmap (bytes)	Tree Bitmap (bytes/prefix)
Single-Trie	409,937	14.8	124,241	4.5	285,696	10.3
Split-Trie	298,822	10.8	124,241	4.5	174,582	6.3

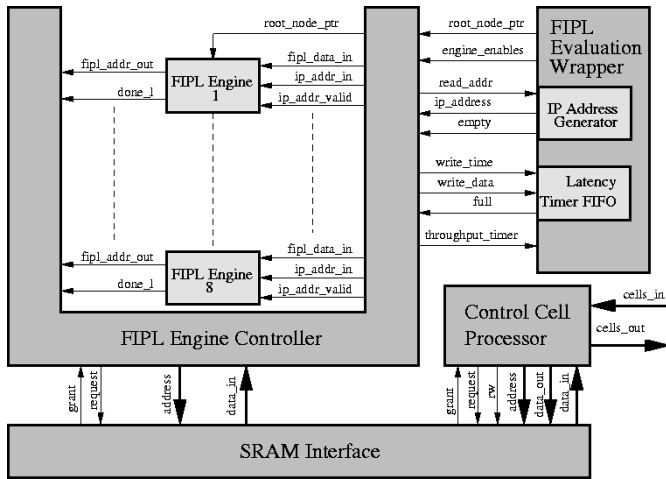

Fig. 13. Block diagram of FIPL evaluation environment.

in the Xilinx FPGA to implement storage for 16 384 IPv4 destination addresses. The IP address generator interfaces to the FIPL engine controller like a FIFO. When a test run is initiated, an empty flag is driven to FALSE until all 16 384 addresses are read.

Control cells sent to the FIPL evaluation wrapper initiate test runs of 16 384 lookups and specify how many FIPL engines should be used during the test run. The FIPL engine controller contains a latency timer for each FIPL engine and a throughput timer that measures the number of clock cycles required to complete each lookup and the test run of 16 384 addresses, respectively. Latency timer values are written to a FIFO upon completion of each lookup. The FIPL evaluation wrapper packs latency timer values into control cells which are sent back to the system control software where the contents are dumped to a file. The throughput timer value is included in the final control cell.

A snapshot of the Mae-West database from March 15, 2002, consisting of 27 609 routes, was used for all tests. The on-chip memory read by the IP address generator was initialized with 16 384 IPv4 destination addresses created via random selections from the route table snapshot. Two evaluation environments were synthesized, one including “single-trie” FIPL engines and one including “split-trie” FIPL engines. Each evaluation environment was downloaded to the RAD FPGA of the FPX and subjected to a series of test vectors.

A. Memory Utilization

Two Tree Bitmap data structures were generated from the Mae-West snapshot, one for the “single-trie” FIPL engines and one for the “split-trie” FIPL engines. As previously mentioned, our experimental implementation allocated an entire 36-bit memory word for next hop information. As shown in Table I,

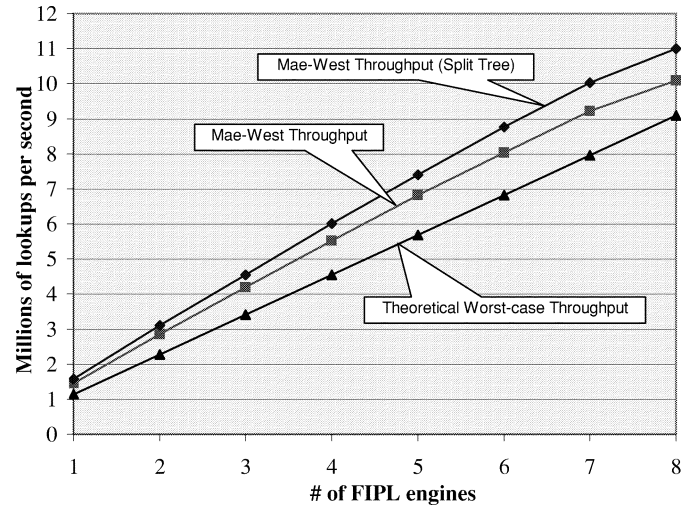

Fig. 14. FIPL performance: measurements used a snapshot of the Mae-West database from March 15, 2002, consisting of 27 609 routes. Input IPv4 destination addresses were created by randomly selecting 16 384 prefixes from the Mae-West database.

the total memory utilization for each variation of the data-structure is broken down into usage for the Tree Bitmap and next hop information. Note that the size of the Tree Bitmap data structure is reduced by approximately 30% via the split-trie optimization.

B. Lookup Rate

Two evaluation environments were synthesized: one including “single-trie” FIPL engines and one including “split-trie” FIPL engines. Each evaluation environment was downloaded to the RAD FPGA of the FPX and subjected to a series of test vectors. The Tree Bitmap data structure generated from the Mae-West database of 27 609 routes was loaded into the off-chip SRAM. The on-chip memory read by the IP address generator was initialized with 16 384 IPv4 destination addresses created via random selections from the route table snapshot. Test runs were initiated using configurations of one through eight engines.

Each evaluation environment was first tested with no intervening updates. Fig. 14 plots the number of lookups per second versus the number of parallel FIPL engines for the single-trie and split-trie versions. The theoretical worst-case performance is also included for reference. With no intervening update traffic, lookup throughput for the “single-trie” configuration ranged from 1.46 million lookups/s for a single FIPL engine to 10.09 million lookups/s for eight FIPL engines; an 11% increase in performance over the theoretical worst case. Under identical conditions, lookup throughput for the “split-trie” configuration ranged from 1.58 million lookups/s for a single FIPL

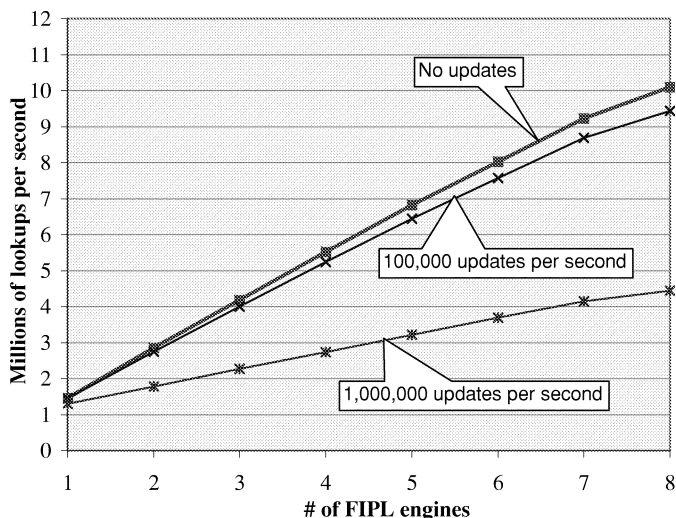

Fig. 15. FIPL performance under update load: measurements used a snapshot of the Mae–West database from March 15, 2002, consisting of 27 609 routes. Input IPv4 destination addresses were created by randomly selecting 16 384 prefixes from the Mae–West database. Updates consisted of alternating addition and deletion of a 24-bit prefix.

engine to 11 million lookups/s for eight FIPL engines; a 9% increase in performance over the “single-trie” configuration. Average lookup latency for “single-trie” FIPL engines ranged from 656 ns for a single FIPL engine to 674 ns for eight FIPL engines. Average lookup latency for “split-trie” FIPL engines ranged from 603 ns for a single FIPL engine to 619 ns for eight FIPL engines.

In order to evaluate performance under update load, updates were transmitted to the evaluation environment at various rates during test runs. Update traffic consisted of an alternating pattern of a 24-bit prefix add a 24-bit prefix delete. For the “single-trie” configuration, the 24-bit prefix add required 25 memory write operations which were packed into four control cells. The 24-bit prefix delete required 14 memory write operations which were packed into three control cells. For the “split-trie” configuration, the 24-bit prefix add required 21 memory write operations which were packed into four control cells. The 24-bit prefix delete required 12 memory write operations which were packed into two control cells. Test runs were executed for both configurations with updates rates ranging from 1000 updates/s to 1 000 000 updates/s. Note that the upper end of the range, one update per microsecond, represents a highly unrealistic situation as update frequencies rarely exceed 1000 updates/s.

Results of test runs of the “single-trie” FIPL configuration with intervening update traffic are shown in Fig. 15. Results of test runs of the “split-trie” FIPL configuration with intervening update traffic are shown in Fig. 16. For both configurations, update frequencies up to 10 000 updates/s had no noticeable effect on lookup throughput performance. For an update frequency of 100 000 updates/s, the “single-trie” configuration exhibited a maximum performance degradation of 6.5% while the “split-trie” throughput was reduced by 7.2%. For an update frequency of 1 000 000 updates/s, the “single-trie” configuration exhibited a maximum performance degradation of 56% while the “split-trie” throughput was reduced by 58.9%. FIPL not only demonstrates no noticeable performance degradation

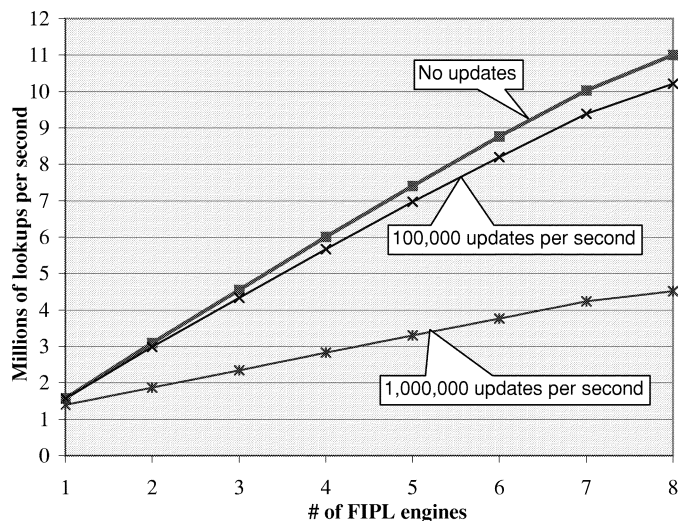

Fig. 16. FIPL split-trie performance under update load: measurements used a snapshot of the Mae–West database from March 15, 2002, consisting of 27 609 routes. Input IPv4 destination addresses were created by randomly selecting 16 384 prefixes from the Mae–West database. Updates consisted of alternating addition and deletion of a 24-bit prefix.

under normal update loads, but it also remains robust under excessive update loads.

Based on the test results, a FIPL configuration employing four parallel search engines was synthesized for the WUGS/FPX research platform in order to support 2-Gb/s links. Utilizing custom traffic generators and bandwidth monitoring software, throughput for minimum length packets was measured at 1.988 Gb/s. Note that the total system throughput is limited by the 32-bit WUGS/FPX interface operating at 62.5 MHz. Additional tests injected route updates to measure update performance while maintaining 2 Gb/s of offered lookup traffic. The FIPL configuration experienced only 12% performance degradation at update rates of 200 000 updates/s.

VII. TOWARDS BETTER PERFORMANCE

Ongoing research efforts seek to leverage the components and insights gained from implementing FIPL on the open research platforms developed at Washington University in Saint Louis. The first effort works to increase the performance of FIPL via design and device optimizations. Other efforts seek to increase the performance and efficiency of FIPL via data structure optimizations to reduce off-chip memory accesses. Finally, FIPL search engines are being incorporated into a classification and route lookup system for the multiservice router project at Washington University [3].

A. Implementation Optimizations

Coupled with advances in FPGA device technology, implementation optimizations of critical paths in the FIPL engine circuit hold promise of increasing the system clock frequency in order to take full advantage of the memory bandwidth offered by modern SRAMs. Existing DDR SRAMs are capable of operating at 200 MHz with the equivalent of two read operations per cycle. Note that modern FPGAs are capable of running at this

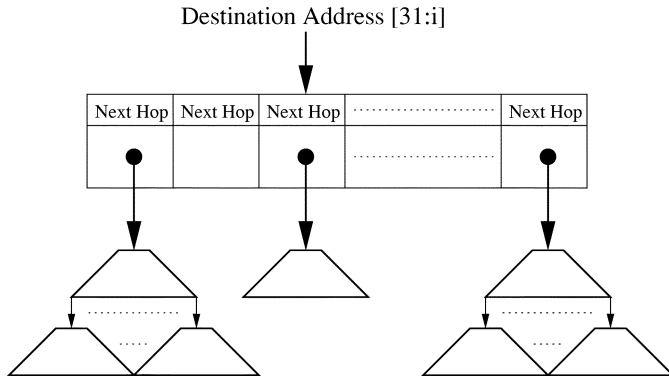

Fig. 17. Root node extension using an on-chip array and multiple sub-tries.

frequency and no throughput is gained via an ASIC implementation since off-chip SRAM accesses are the performance bottleneck. Doubling of the clock frequency of FIPL, employing 16 engines, and using a DDR SRAM directly translates to a factor of four increase in lookup performance to a guaranteed worst-case throughput of over 36.4 million lookups/s.

B. Root Node Extension and Caching

By both caching the root node and extending its stride length, the number of off-chip memory accesses can be reduced. Extending the stride length of the root node increases the number of bits required for the extending paths and internal prefix bitmaps. The increase in the number of extending paths also requires a larger chunk of contiguous memory for storing the child node array. In general, the number of bitmap bits required for a stride of length n is $2^{n+1} - 1$. The maximum number of contiguous memory spaces needed for the child node array is 2^n .

Selecting the stride length for the cached root node mainly depends upon the amount of available on-chip memory and logic. In the case of ample on-chip memory, one would still want to bound the stride length to prevent the amount of contiguous memory spaces necessary for the child node array from becoming too large. Selection of a stride length which is a factor of four plus one (i.e., 5, 9, 13, ...) provides the favorable property of implementing the “multiple-of-stride” case efficiently. Selecting a root node stride length of eight requires extending paths and internal prefix bitmap lengths of 8192 and 8191 bits, respectively. Given that current generations of FPGAs implement 16 kb blocks of memory, the bitmap storage requirement does not seem prohibitively high. However, the *CountOnes* and *Tree Search* functions consume exorbitant amounts of logic for such large bitmaps.

Another approach is to simply represent the root node as an on-chip array indexed by the first i bits of the destination address, where i is determined by the stride length of the root node. As shown in Fig. 17, each array entry stores the next hop information for the best-matching prefix in the n -bit path represented by the index, as well as a pointer to an extending path subtree. Searches simply examine the extending path subtree pointer to see if a subtree exists for the given address. This may be done by designating a null pointer value or using a valid extending path bit. If no extending path subtree exists, the next hop information

TABLE II
MEMORY USAGE FOR ROOT NODE ARRAY OPTIMIZATION

Stride (i)	As	On-CM (bits, BRAMs)	WC Off-CMA	WC Tp (10ns, 5ns)
4	16	512 (1)	10	10, 20
5	32	1024 (1)	10	10, 20
8	256	8,192 (2)	9	11.1, 22.2
9	512	16,384 (4)	9	11.1, 22.2
12	4096	131,072 (32)	8	12.5, 25
13	8192	262,144 (64)	8	12.5, 25

stored in the on-chip array entry is applied to the packet. If an extending path subtree exists, the extending path subtree pointer is used to fetch the “root node” of the extending path subtree and the search continues in the normal Tree Bitmap fashion. If no matching prefix is found in the subtree, the next hop information stored in the on-chip array entry is applied to the packet.

Obviously, the performance gain comes at the cost of on-chip resource usage. Table II shows the following:

- *Array Size (AS)*: number of array slots;
- *On-chip Memory (On-CM)*: the amount of on-chip memory needed (in terms of bits and number of BlockRAMs required in the Virtex-E target device) in order to allocate the root node array;
- *Worst-Case Off-chip Memory Accesses (WC Off-CMA)*: the amount of off-chip memory required to store subtrees;
- *Worst-Case Throughput (WC Tp)*: millions of lookups per second assuming a 100 MHz clock ($T = 10$ ns) and 200 MHz clock ($T = 5$ ns).

Note it is assumed that all subtree pointers and next hop information are 16 bits each. If more next-hop information is required, the on-chip memory may be scaled accordingly or the information may be stored off-chip and the 16-bit field used as a pointer.

Future research will seek to more fully characterize this design option by determining the following:

- *On-chip Memory Usage (On-CMU)*: the number and percentage of occupied array slots;
- *Off-chip Memory Usage (Off-CMU)*: the amount of off-chip memory required to store subtrees;
- *Throughput (Tp)*: lookups per second when using a backbone routing table snapshot.

VIII. CONCLUSION

IP address lookup is one of the primary functions of the router and often is a significant performance bottleneck. In response, we have presented the fast Internet protocol lookup (FIPL) architecture which utilizes Eatherton and Dittia’s Tree Bitmap algorithm. Striking a favorable balance between lookup and update performance, memory efficiency, and hardware resource usage, each FIPL engine supports over 500 Gb/s of link traffic while consuming less than 1% of available logic resources and approximately 10 bytes of memory per entry. Utilizing only a fraction of a reconfigurable logic device and a single commodity SRAM, FIPL offers an attractive alternative to expensive commercial solutions employing multiple content addressable memory (CAM) devices and application specific integrated circuits (ASICs). By providing high performance at low per-port

costs, FIPL is a prime candidate for system-on-chip (SoC) solutions for efficient next-generation Internet routers.

ACKNOWLEDGMENT

The authors would like to acknowledge W. Eatherton and Z. Dittia as the developers of the Tree Bitmap algorithm. Their design efforts and analyses made this research possible. They would like to thank T. Evans and E. Spitznagel for their contributions to the FIPL memory manager software, as well as J. DeHart for his invaluable assistance with system verification and performance measurements.

REFERENCES

- [1] S. Fuller, T. Li, J. Yu, and K. Varadhan, "Classless inter-domain routing (CIDR): An address assignment and aggregation strategy," *RFC 1519*, Sept. 1993.
- [2] W. N. Eatherton, "Hardware-based Internet protocol prefix lookups," M.S. thesis, Washington Univ., St. Louis, MO, 1998. [Online]. Available: www.arl.wustl.edu.
- [3] S. Choi, J. Dehart, R. Keller, F. Kuhns, J. Lockwood, P. Pappu, J. Parwatikar, W. D. Richard, E. Spitznagel, D. Taylor, J. Turner, and K. Wong, "Design of a high performance dynamically extensible router," in *Proc. DARPA Active Networks Conf. Exposition*, San Francisco, CA, May 2002, pp. 42–64.
- [4] P. Gupta, S. n Lin, and N. McKeown, "Routing lookups in hardware at memory access speeds," in *Proc. IEEE INFOCOM*, San Francisco, CA, 1998, pp. 1240–1247.
- [5] S. Nilsson and G. Karlsson, "Fast address lookup for Internet routers," in *Proc. IFIP Int. Conf. Broadband Communications*, Stuttgart, Germany, 1998, pp. 11–22.
- [6] V. Srinivasan and G. Varghese, "Faster IP lookups using controlled prefix expansion," in *Proc. SIGMETRICS*, Madison, WI, 1998, pp. 1–10.
- [7] M. Degermark, A. Brodnik, S. Carlsson, and S. Pink, "Small forwarding tables for fast routing lookups," in *Proc. ACM SIGCOMM*, Cannes, France, 1997, pp. 3–14.
- [8] SiberCore Technologies Inc., SiberCAM Ultra-2M SCT2000, 2000.
- [9] M. Waldvogel, G. Varghese, J. Turner, and B. Plattner, "Scalable high speed IP routing table lookups," in *Proc. ACM SIGCOMM '97*, Sept. 1997, pp. 25–36.
- [10] Gigabit Technology Distribution Program, J. S. Turner. (1999, Aug.). [Online]. Available: <http://www.arl.wustl.edu/gigabitkits/kits.html>
- [11] J. Turner, T. Chaney, A. Fingerhut, and M. Flucke, "Design of a gigabit ATM switch," in *Proc. INFOCOM 97*, Kobe, Japan, Mar. 1997, pp. 2–11.
- [12] S. Choi, J. Dehart, R. Keller, J. W. Lockwood, J. Turner, and T. Wolf, "Design of a flexible open platform for high performance active networks," in *Proc. Allerton Conf.*, Champaign, IL, 1999.
- [13] J. W. Lockwood, J. S. Turner, and D. E. Taylor, "Field programmable port extender (FPX) for distributed routing and queuing," in *Proc. ACM Int. Symp. Field Programmable Gate Arrays (FPGA'2000)*, Monterey, CA, Feb. 2000, pp. 137–144.
- [14] J. W. Lockwood, N. Naufel, J. S. Turner, and D. E. Taylor, "Reprogrammable network packet processing on the field programmable port extender (FPX)," in *Proc. ACM Int. Symp. Field Programmable Gate Arrays (FPGA'2001)*, Monterey, CA, Feb. 2001, pp. 87–93.
- [15] P. Newman *et al.*, "Transmission of flow labeled IPv4 on ATM data links," *Internet RFC 1954*, May 1996.
- [16] T. S. Sproull, J. W. Lockwood, and D. E. Taylor, "Control and configuration software for a reconfigurable networking hardware platform," in *Proc. IEEE Symp. Field-Programmable Custom Computing Machines (FCCM'02)*, Apr. 2002, pp. 45–54.
- [17] J. M. Anderson, M. Ilyas, and S. Hsu, "Distributed network management in an internet environment," in *Proc. GLOBECOM'97*, vol. 1, Phoenix, AZ, Nov. 1997, pp. 180–184.
- [18] Internet Routing Table Statistics (2001, May). [Online]. Available: http://www.merit.edu/ipma/routing_table/



David E. Taylor received the B.S. and M.S. degrees in electrical and computer engineering from Washington University in Saint Louis, St. Louis, MO, in 1998 and 2002. He is currently working toward the Ph.D. degree in electrical engineering, at the same university.

He is a Research Assistant at the Applied Research Laboratory, Washington University in Saint Louis. He held a Research Internship with the network processor hardware group at the IBM Zurich Research Laboratory during the summer of 2002. His research interests include algorithms and architectures for IP lookup, packet classification, and high-performance reconfigurable hardware systems.



Jonathan S. Turner (M'77–SM'88–F'90) received the M.S. and Ph.D. degrees in computer science from Northwestern University, Evanston, IL, in 1979 and 1981.

He holds the Henry Edwin Sever Chair of Engineering at Washington University in Saint Louis, St. Louis, MO, and is Director of the Applied Research Laboratory. The Applied Research Laboratory is currently engaged in a variety of projects ranging from dynamically extensible networks to optical burst switching. He served as Chief Scientist for Growth Networks, a startup company that developed scalable switching components for Internet routers and ATM switches, before being acquired by Cisco Systems in early 2000. His primary research interest is the design and analysis of switching systems, with special interest in systems supporting multicast communication. His research interests also include the study of algorithms and computational complexity, with particular interest in the probable performance of heuristic algorithms for NP-complete problems. He has been awarded more than 20 patents for his work on switching systems and has many widely cited publications.

Dr. Turner received the Koji Kobayashi Computers and Communications Award from the IEEE in 1994 and the IEEE Millennium Medal in 2000. He is a Fellow of ACM.



John W. Lockwood (S'89–M'96) received the B.S., M.S., and Ph.D. degrees in electrical and computer engineering from the University of Illinois, Urbana, IL.

He is a Professor of computer science at Washington University in Saint Louis, St. Louis, MO. He designs and implements networking systems in reconfigurable hardware. Through his work in the Applied Research Laboratory, he and his research group developed the Field programmable Port Extender (FPX) to enable rapid prototype of extensible network modules in Field Programmable Gate Array (FPGA) technology. He has worked in industry at the networking groups of IBM, AT&T Bell Laboratories, and the National Center for Supercomputing Applications (NCSA). He served as the Program Chair for Hot Interconnects in 2002 and currently serves as the General Chair for the upcoming Hot Interconnects Conference to be held in 2003. He also serves as Program Chair for the upcoming International Conference on Microelectronic Systems Education (MSE), and served on the Technical Program Committee for the International Working Conference on Active Networks (IWAN).

Dr. Lockwood has served as a Reviewer for the IEEE JOURNAL ON SELECTED AREAS IN COMMUNICATIONS (JSAC), IEEE TRANSACTIONS ON VERY LARGE SCALE INTEGRATION SYSTEMS (TVLSI), ACM *Transactions on Embedded Systems* (TECS), ACM SIGMETRICS, *Computer Networks Journal*, and GLOBECOM. He is a Member of ACM, Tau Beta Pi, and Eta Kappa.



Todd S. Sproull received the B.S. degree in electrical engineering from Southern Illinois University, Edwardsville, in 2000 and the M.S. degree in computer engineering from Washington University in Saint Louis, St. Louis, MO, in 2002. He is working toward the Ph.D. degree in computer engineering, at the same university.

He is a Research Assistant at the Applied Research Laboratory, Washington University in Saint Louis. He held an Internship with the startup Network Physics during the summer of 2001. His research and configuration of reprogrammable systems and

interests include control and distributed computing.



David B. Parlour (S'77–M'76) received the B.S. degree in engineering from Carleton University, Ottawa, ON, Canada, in 1980 and the M.S. degree from the California Institute of Technology, Pasadena, in 1981.

In 1990, he joined Xilinx Inc., San Jose, CA, where he has worked on a variety of projects involving the design of circuits, architectures, tools and methodology for field programmable gate arrays. He is currently a Member of Xilinx Research Labs, where his area of research is domain-specific high level tools

for FPGA design.